

# NAGRA ARES-BB<sup>+</sup> MANUAL



PROFESSIONAL AUDIO



# CONTENTS

Page

1 DELIVERED WITH.....	4
2 INSTALLING THE BATTERIES (NB-BB OPTION).....	4
3 INSTALLING THE FLASHCARD.....	5
4 POWER ON, POWER OFF.....	5
5 CONTRAST.....	5
6 KEYS.....	6
7 FAT / NFS MODE DIFFERENCES.....	6
8 FIRST TIME SWITCH ON.....	7
9 MAIN DISPLAY DESCRIPTION.....	7
10 RECORD (2), REWIND (3), STOP (4), PLAY (5), FORWARD (6), MARK (14) KEYS.....	8
10.1 RECORD KEY (2).....	8
10.2 REWIND KEY (3) AND FORWARD KEY (6).....	8
10.3 STOP KEY (4).....	9
10.4 PLAY KEY (5).....	9
10.5 EXTERNAL RECORD OR FADER START COMMAND.....	9
11 LEVEL ADJUSTMENT.....	9
11.1 OUTPUT LEVEL ADJUSTMENT.....	9
11.2 INPUT LEVEL ADJUSTMENT.....	9
11.3 THRESHOLD ADJUSTMENT.....	10
11.4 WHAT IS DBSPL.....	10
12 CENTER & ARROW KEYS.....	11
13 LED MODULOMETER.....	11
14 MAIN MENU.....	11
14.1 DIRECTORY MENU.....	11
14.1.1 HORIZONTAL SCROLLING.....	13
14.1.2 VERTICAL SCROLLING.....	13
14.1.3 QUIT DIRECTORY.....	13
14.1.4 EDIT INDEX.....	14
14.1.5 DELETE.....	17
14.1.6 DELETE TO END.....	17
14.1.7 RENUMBER.....	17
14.1.8 RENUMBER ALL.....	17
14.1.9 DELETE ALL MARKS.....	17
14.2 LOUDSPEAKER.....	17
14.3 TOOLS.....	17
14.3.1 LANGUAGE.....	17
14.3.2 FILE NAMING.....	17
14.3.3 DATE AND TIME.....	19
14.3.4 CARD FORMATTING.....	19
14.3.5 BATTERY TYPE.....	19
14.3.6 PROGRAM SELECT.....	19
14.3.7 CONTRAST.....	20
14.3.8 AUTO POWER OFF.....	20

14.3.9 VERSION.....	20
14.4 TEMPLATES.....	20
14.5 SETTINGS MENU.....	21
14.5.1 INPUT FILTER.....	21
14.5.2 ALC.....	21
14.5.3 ALC THRESHOLD.....	21
14.5.4 ALC REACTION SPEED.....	22
14.5.5 INPUT LEVEL.....	22
14.5.6 BEEP.....	22
14.5.7 FILE FORMAT.....	22
14.5.8 BACKLIGHT.....	22
14.5.9 OUTPUT MODE.....	22
14.5.10 OUTPUT LEVEL.....	22
14.5.11 MS DECODER.....	23
14.5.12 START / STOP CONFIGURATION.....	23
14.5.13 AUTOMATIC SKIP.....	23
14.5.14 RED LED LEVEL.....	23
14.6 AUTO RECORD.....	24
14.7 INPUT.....	24
14.7.1 INPUT TYPE.....	24
14.7.2 48V MIKE POWER.....	25
15 LOCKING THE SETTINGS.....	25
16 LOCKING THE KEYPAD.....	25
17 AUTO POWER OFF.....	25
18 MESSAGES.....	25
19 SOFTWARE UPDATE.....	26
20 MENU TREE ARES-BB <sup>+</sup> .....	27
21 INPUTS, OUTPUTS.....	31
21.1 INPUT SIDE.....	31
21.2 OUTPUT SIDE.....	31
22 ARES-BB <sup>+</sup> PC SOFTWARE & INSTALLATION (NFS MODE).....	32
22.1 ARES-BB <sup>+</sup> SOFTWARE, USING A PC PCMCIA SLOT (NFS MODE)....	32
22.2 ARES-BB <sup>+</sup> SOFTWARE, USING A PC USB PORT (NFS MODE).....	32
23 ARES-BB <sup>+</sup> PC DRIVERS & INSTALLATION (FAT MODE).....	33
24 FLASH CARDS COMPATIBILITY.....	34
25 LANGUAGES.....	35
26 SPECIFICATIONS.....	43
27 SAFETY/COMPLIANCE.....	44

**This manual describes the use of the ARES-BB<sup>+</sup> in the FAT mode.**

**For using the Ares-BB<sup>+</sup> in the NFS mode, please refer to the previous Ares-P II manual or to the Ares-P / RCX220 manual.**

## **1 DELIVERED WITH.**

1 Jack 6.3 mm (90 degrees) connector, 1 USB cable, 1 CDR with Ares Import, Digigram import software and manuals.

## **2 INSTALLING THE BATTERIES (NB-BB OPTION).**

On the rear side of the machine, loose the 2 “thumb” screws until the battery box can be removed. To open the battery compartment, slide the inner cover until it is fully open. If dry cells are used verify that the battery compartment switch is in the OFF position. Install the 6 “AA” cells observing the polarity and replace the inner cover. Lock the battery compartment back to the machine.

Batt. Type	Capacity	Charging time	Record mode	Manufactory
NimH	1300 mAh	4h30	5h30	GP
NimH	2300 mAh	8h00	11h35	Sanyo
Li-Ion	2400 mAh	8h30	12h30	Saft
Dry cells		x	12h50	Panasonic, Alkaline

### **Note:**

If the batteries make a noise (due to the Ø tolerances) when the housing is shaken, glue the added Mylar sheet as indicated in the picture and insert the batteries as shown.

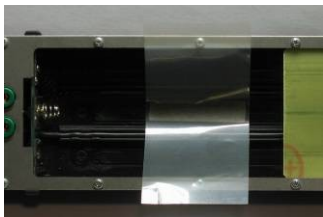

### **Important note:**

In the tools sub-menus select the corresponding type of battery pack (AA cells or Li-ion)

When using the external power supply, check that the switch on the battery compartment is set to “OFF” before installing dry cells.

In the OFF position, the charger circuitry is not activated and if an external power supply is connected, the machine will run from external supply and not from the batteries.

When an external power supply is connected to the Ares-BB<sup>+</sup>, the green led turns on. During charge, the yellow led turns on. The Ares-BB<sup>+</sup> charges with approx. 300 mA. Charging stops automatically (yellow led turns off). If the yellow led never turns off, it means that one or more cells are defective. If the charger switch is turned on and no batteries are installed while the machine receives external power, the yellow led starts blinking fast.

### 3 INSTALLING THE FLASHCARD.

Insert the flashcard on the right side of the machine and push it fully home (eject button fully out). Compact flash cards must be installed using an adapter.

**NOTE:** The software version, for the Ares-BB\* allows, ATA cards, compact flash cards and Micro-drive cards. Linear flash cards and Strata flash cards can only be used in the NFS mode (Nagra File Format).

#### **Important note:**

When running the machine in the FAT mode, only ATA, Compact flash cards and Micro-drive cards can be used.

### 4 POWER ON, POWER OFF.

Press the "**POWER ON**" button (1) for 1 second and the machine switches on. To switch "**OFF**" the machine push the same button again for 1 second. Once the main display is shown, the type of selected file system and file format are shown briefly. To re-indicate the selected file format, press the "**POWER**" key (1) briefly at any time. (Ex. PCM 48k 16b st).

**Attention:** the machine cannot be switched OFF during RECORD or EDITING.

### 5 CONTRAST.

If the display contrast is not set properly at power on, switch off the machine, keep the "**RIGHT**" arrow key (12) pressed while turning on the machine. This brings the machine directly to the contrast menu. Adjust step-by-step with the "**UP**" (9) or "**DOWN**" (11) arrow keys to increase or decrease accordingly. Once the correct contrast is found, press the "**CENTER**" key (13) to store the new setting in the machine. Press the "**LEFT**" arrow key (10) to quit the menus. The factory setting has the value "32".

## 6 KEYS.



1	Power ON / OFF	9	Up arrow key or increase output level key
2	Record, Marker key	10	Left arrow key
3	Rewind, skip backwards key	11	Down arrow key or reduce output level key
4	Stop key	12	Right arrow key
5	Play key	13	Other menu or execute key
6	Forward, skip forwards key	14	Mark key
7	Reduce input sensitivity or playback level key	15	Keypad lock
8	Increase input sensitivity or playback level key		

## 7 FAT / NFS MODE DIFFERENCES.

The **"FAT"** mode means that the ATA or Compact flash card is formatted according to the FAT standard (FAT 16 or FAT 32) and is directly compatible with a Windows or Mac O/S. The **"NFS"** mode means that the card is formatted with a Nagra format (Nagra File System), in order to remain compatible with previous machines such as the Ares-C, C-PP, Ares-P or RCX220. To read a card formatted NFS in a PC, additional PC software is needed.

If no software options are installed, the card will be formatted **"FAT"** and via the USB port, Windows or Mac O/S will recognize the machine as an external hard disk. The recorded files are Broadcast Wave Format (xxx.wav). Only PCM linear can be recorded (not compressed). Only ATA or Compact flash cards can be used in the **"FAT"** mode.

If equipped with the software option #I, the machine emulates an ARES-P (NFS mode) and allows MPEG compressed files to be recorded in both the FAT or NFS modes. In the **"NFS"** mode, the maximum bit rate is 192kb/s, in the **"FAT"** mode, the maximum bit rate is 384kb/s.

If equipped with software option #I & #II, the machine also emulates an RCX220. This means that through the USB port, Windows recognizes the machine as an external soundcard when in **"NFS"** mode and as an external removable hard drive in the **"FAT"** mode.

**Important note:** When making linear recordings (WAV) the range of media that can be used is restricted. The card must be capable of writing data at high speed. A stereo recording at 48kHz requires a data rate of  $2 \times 24 \text{ bits} \times 48000 \text{ sampling frequency} \div 8 \text{ bits per Byte}$  gives a data rate of 288 kBytes per second.

## 8 FIRST TIME SWITCH ON.

Verify first that the keypad lock switch (15) is in the left position. Once the batteries have been installed and turning on, the machine will switch on in the "FAT" mode. The display will show a picture of a cylinder with the word "FAT" for several seconds.

If the words "Nagra File System" appear (only if minimum the soft #1 package is included) jump to page 17 Paragraph 14.3.3 PROGRAM SELECT before continuing.

## 9 MAIN DISPLAY DESCRIPTION.

Attention: At power on, the display below is shown, but without the level bargraph indicator on the right-hand side. This bargraph appears when the "+" or "-" button (8 or 7) is pressed. It disappears after a few seconds to improve the clarity of the display.

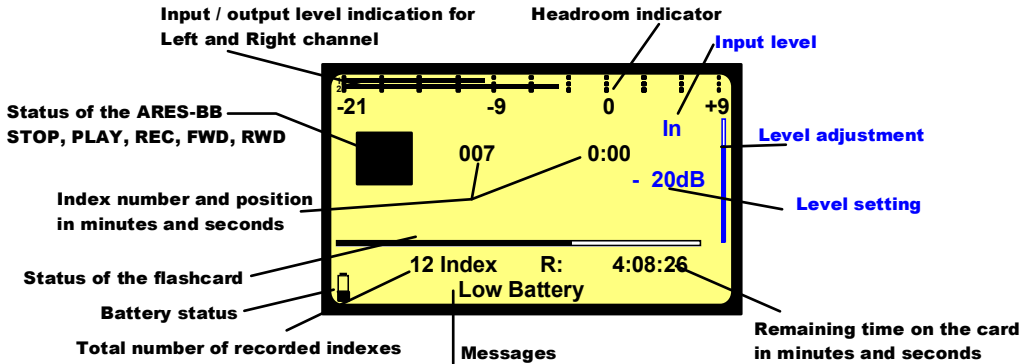

### Status of the ARES-BB<sup>+</sup>



- |                   |  |
|-------------------|--|
| "STOP"            | ARES-BB <sup>+</sup> is in STAND BY mode       |
| "RECORD"          | ARES-BB <sup>+</sup> is in RECORD mode         |
| "PLAY"            | ARES-BB <sup>+</sup> is in PLAY mode           |
| "SEARCH FORWARD"  | ARES-BB <sup>+</sup> is playing fast forwards  |
| "SEARCH BACKWARD" | ARES-BB <sup>+</sup> is playing fast backwards |

### Take / Index number and position in minutes and seconds

This is the physical playback position. The example shows that playback will start at the beginning of Take / Index 7 (0 minutes, 0 seconds).

### Status of the flashcard

The full length of the bargraph corresponds to the total memory of the inserted flashcard. The black area shows how much memory was already used for recording. The clear area shows the remaining memory.

### Total number of recorded Takes / Indexes

This area shows the total number of Takes / Indexes already recorded on the flashcard.

### Remaining time on the card in minutes and seconds

This indicates how much recording time is left on the card. In this example, it shows 4 hours 8 minutes, 26 seconds. If the bit-rate is changed, it will automatically be updated. Example 4:8:26 if 128kb/s was set, it will become 8:16:52 if the bit-rate was changed to 64kb/s.

## Input / output level indication for Left and Right channel

In the stereo mode, bargraph 1 corresponds to the left channel and 2 to the right channel. In mono mode, both bargraphs indicate the input / output level. From 0dB, the bargraph shows the headroom up to +9dB. +9dB corresponds to "FF" for the AD converter.

## Messages

This is the area for messages, such as "**LOW BATTERY**", "**CARD FULL**" etc.

A beep in the headphones corresponds to an arrival of a message on the display.

When pressing shortly the "**POWER**" key, the message area will show the file format selected for recording.

## Battery status

When the battery icon shows full, it indicates the batteries are charged. When the voltage drops below the first internal reference, a warning beep is heard in the headphones and the message "**LOW BATTERY**" appears in the display. When the voltage drops below the second internal reference, the machine automatically switches off.

When the battery icon disappears during a USB connection in the "FAT" mode, it means that the machine is powered by the PC and not anymore by the internal batteries or external power supply.

## Level Adjustment

This bargraph only appears on the screen during the adjustment of the input sensitivity, the output level or the ALC threshold adjustment. If no adjustment is made it will disappear after a few seconds.

Simultaneously, the level setting in dB's as well as the kind of adjustment "**IN**", "**OUT**" or "**THR**" will appear on the display.

## 10 RECORD (2), REWIND (3), STOP (4), PLAY (5), FORWARD (6), MARK (14) KEYS

### 10.1 RECORD KEY (2)

To start recording, the "**RECORD**" key (2) can be pressed, even if the machine was in "**PLAY**" mode or is in one of the sub-menus. The "**RECORD**" key will not work if the machine is formatting the card.

If during record the "**RECORD**" key is pressed again, a new Take / Index is automatically created.

During record or play, the "**MARK**" key (14) can be pressed on the fly.

**Important:** Those marks can be used on an external editing system (Dalet, Netia, Digas, VCS etc.) and are also used as cut positions on the internal editing system of the ARES-BB<sup>+</sup> (Option #3).

During record, the front red LED turns ON.

During record, the "**POWER**" (1) key as well as the "**REWIND**" (3), "**PLAY**" (5) and "**FORWARD**" (6) keys are disabled.

### 10.2 REWIND KEY (3) AND FORWARD KEY (6) SKIP.

These keys have two functions called "**SKIP**" backwards or forwards and "**REWIND**" or "**FORWARD**".

To jump index-by-index, pressing briefly on the "**REWIND**" (3) or the "**FORWARD**" (6) keys will decrement or increment the index position.

To jump index-by index, pressing briefly the "**REWIND**" (3) or the "**FORWARD**" (6) keys followed by holding the same key will fast decrement or increment the index position.

**IMPORTANT:** Only indexes with the same sampling frequency as the current settings of the machine can be played back using the SKIP keys. All other indexes with a different sampling frequency cannot be selected.

If the recording contains "**MARKS**" then these keys will jump to the next (or previous) mark position.

## **FORWARD SEARCH & BACKWARD SEARCH.**

This function can be executed in “**STOP**” or “**PLAY**” mode. Once the “>>” or “<<” key is pressed for more than 0.5 seconds, the machine starts “**FORWARD or BACKWARDS SEARCH**” at 4 times nominal speed. The longer the button is pressed, the search speed increments up to 128 times nominal speed. When the button is released, the search stops and it returns to its previous function (STOP or PLAY).

### **10.3 STOP KEY (4)**

When this key is pressed during record or playback, the machine stops recording or playing and returns to the “**EE**” mode.

The “**EE**” mode means that the input signal is fed to the output. This button can also be used as the “**PAUSE**” key during playback.

### **10.4 PLAY KEY (5)**

After a record session pressing the “**PLAY**” key, immediately plays back the last recorded Take / Index.

### **10.5 EXTERNAL RECORD OR FADER START COMMAND**

On the right side of the machine, a mini jack connector (mono 3.5 mm) is present called “**START / STOP**”. Depending on the selection made in the menus, if the mini jack input is grounded, the record or playback starts, if open, the record or playback stops.

## **11 LEVEL ADJUSTMENT**

### **11.1 OUTPUT LEVEL ADJUSTMENT**

During the “**STOP**” or “**RECORD**” mode, the output level can be adjusted by the “**UP ARROW**” key (9) to increase or the “**DOWN ARROW**” key (11) to decrease. Once one of these keys is pressed, an additional bargraph on the right side of the display appears, indicating “**OUT**”, showing the current position of the adjustment. “**0dB**” corresponds to maximum output level, “**-59dB**” corresponds to minimum output level and “**OFF**” corresponds to mute of the output signal.

The setting of the output level can also be stored in the machine in such a way that every time the machine is switched ON, it will take the same “**DEFAULT LEVEL**” output adjustment (See “**SETTINGS MENU, OUTPUT LEVEL**”). During the “**PLAY**” mode, the output level can be adjusted either by the “**UP & DOWN ARROW**” keys (9 & 11) or the “**+**” and “**-**” keys (8 & 7).

### **11.2 INPUT LEVEL ADJUSTMENT**

During “**STOP**” or “**RECORD**”, the input level can be adjusted by pressing the “**+**” (8) or “**-**” (7) keys to increase or decrease the input sensitivity. Once one of these keys is pressed, an additional bargraph on the right side of the display appears, indicating “**IN**”, corresponding to the current setting. “**74dB**” corresponds to maximum input gain, “**133dB**” corresponds to minimum input gain and “**OFF**” corresponds to muting of the input signal. If the input sensitivity is adjusted for “**74dB**”, it means that if the input signal at 74dB SPL will be recorded at a 0dB level.

## Level Adjustment in the stereo mode

When in the sub menus the "INPUT TYPE" is set to "STEREO", the left and right channel can be adjusted separately. Holding the left arrow key (10) and adjusting the input sensitivity will only adjust the left channel. Holding the right arrow key (12) and adjusting the input sensitivity will only adjust the right channel. When the input sensitivity between the 2 channels is not identical, the display will automatically show both input sensitivity levels.

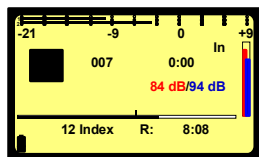

As shown on the picture, the red indications correspond to the left channel, the blue indications correspond to the right channel. If no left or right arrow is pressed during the input sensitivity adjustment, both channels will be adjusted simultaneously and keep the same delta until one of the channels is reaching max. or min. level.

## 11.3 THRESHOLD ADJUSTMENT

If "ALC" (Automatic Level Control) is "ON" and the "ALC THRESHOLD" is set to "USING +/- KEYS" (see SETTINGS MENU, ALC THRESHOLD), the threshold during "RECORD" or "STOP" can be adjusted by pressing the "+" or "-" keys (8 or 7). Once one of these keys is pressed, an additional bargraph on the right side of the display, indicating "THR" appears, showing the current position of the adjustment. "74dB" corresponds to maximum threshold level, "104dB" corresponds to minimum threshold level.

The "THRESHOLD" adjustment permits selection of the size of the compression zone. It is the lower limit setting of the zone that will be automatically amplified during a silent period. The "ALC" works in a range of 42dB (from 74dB to 116dB). If the "THRESHOLD" is set to 104dB, signals of 104dB and higher (max. 116dB) will be recorded at 0dB level (between -2dB and -6dB for a stable signal). A signal of 90dB will be recorded at -14dB (104dB - 90dB).

## 11.4 WHAT IS DBSPL

The term "dB SPL" is the unit used to indicate the power of ambient sound. "dB" is the abbreviation of decibels (ten bels), which is the logarithmic ratio of a signal versus a reference level. "SPL" indicates the reference level and stands for "Sound Pressure Level". The reference level is an air pressure of 20 micropascal (0.00002 Pa = 0 dB SPL).

$$dB = 20 \times \log \left( \frac{\text{signal}}{\text{reference}} \right)$$

### Some indicative values:

- 30-40 dB SPL : ambient room noise / whispering
- 50-70 dB SPL : normal conversation
- 80-90 dB SPL : feature film soundtrack in a theater
- 90-110 dB SPL : busy bar with live music (Swiss legal max is 110 dB in a public arena)
- 110-120 dB SPL : heavy rock concert
- 130-140 dB SPL : Threshold of pain for the human ear

If the gain of the microphone is correctly set, the ARES-BB<sup>+</sup> could be used as a sonometer. The value indicated by the modulometer of the ARES-BB<sup>+</sup> is the peak value (dB SPL<sub>peak</sub>). The peak value is typically 10 dB higher than the RMS (Root Mean Square) value.

### Examples:

Input attenuation set to 90dB, modulometer shows 0dB, this means that the sound has a pressure level of 90dB SPL<sub>peak</sub> ≈ 80 dB SPL.

Input attenuation set to 74dB, modulometer shows -12dB, this means that the sound has pressure level of (74 - 12) 62dB SPL<sub>peak</sub> ≈ 52dB SPL

Finally, if you know that you are going to make a recording of a sound level of 90 dB SPL (100 dB SPL<sub>peak</sub>) then you can pre-adjust your machine by setting the level pot to the 100 db position and in this way, your recording will not overload and you will record at about 0 dB on the modulometer.

## 12 CENTER & ARROW KEYS



By pushing the “**CENTER**” key (13), the machine gives access to the “**DIRECTORY**”, “**LOUDSPEAKER**”, “**TOOLS**”, “**TEMPLATES**”, “**SETTINGS**” etc. sub-menus. Using the “**ARROW**” keys (9 to 12), you navigate between those sub-menus. To move back to the initial display, press the “**LEFT ARROW**” key (10) (except in the “**DIRECTORY**” where “**CENTER**” key (13) needs to be pressed first to return to the sub-menus).

## 13 LED MODULOMETER

The LED modulometer shows the sum of both channels when the machine is set to Stereo operation. The three leds give a quick visual indication in three colours, green, yellow and red. They light at levels of - 21, -9 and standard 0 dB respectively. Normal operation is with the green and yellow led on and the red led flashing occasionally on signal peaks. In the sub-menus, the red led reference can be set to 0, +3, +6 or +9 dB.

## 14 MAIN MENU.

By pressing the “**CENTER**” key (13), the main menu appears on the display.

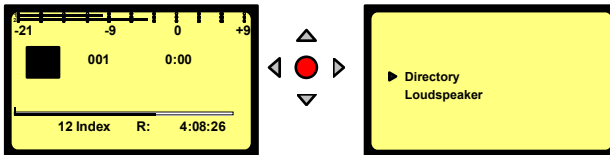

The “**DIRECTORY**” gives access to all the information of the recorded files on the flashcard.

If “**TOOLS**” is selected, other sub menus can be selected: “**FILE NAMING**”, “**DATE & TIME**”, “**CARD FORMATTING**”, “**PROGRAM SELECT**”, “**CONTRAST**” and “**VERSION**”.

If “**SETTINGS**” is selected, several other sub-menus can be selected such as: “**OUTPUT LEVEL**”, “**INPUT FILTER**”, “**BEEP**” and “**FILE FORMAT**” etc.

Scrolling through the different sub-menus is done by pressing the “**DOWN ARROW**” (11) or “**UP ARROW**” (9) keys.

Escaping from the sub-menus is done by pushing the “**LEFT ARROW**” key (10).

Entering a sub-menu is done by pushing the “**RIGHT ARROW**” key (12) or the “**CENTER**” key (13).

Inside a sub-menu, execute the selected setting by pressing the “**CENTER**” key (13).

### 14.1 DIRECTORY MENU.

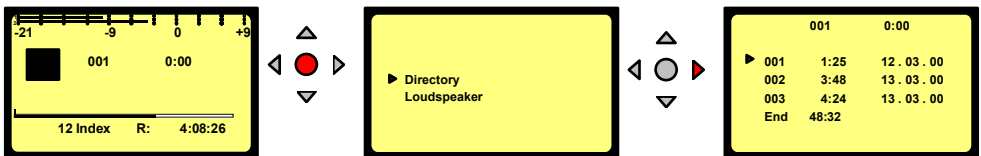

By using the **“UP”**, **“DOWN”**, **“LEFT”**, **“RIGHT ARROW”** keys ( 9, 11, 10, 12), once **“DIRECTORY”** has been selected, it becomes possible to scroll vertically and horizontally to view all the recorded indexes and their specifications.

If the marker has a **“▶”** shape, it means that the index sampling frequency is the same as the current settings of the machine. When in this case, the **“PLAY”** key (5) is pressed, the playback starts immediately. If the **“STOP”** (4) key is not pressed at the end of the playback of this selected index, the playback continues on the next index that has the same sampling frequency as the previous selected index.

If the marker has a **“>”** shape, it means that the index sampling frequency is different from the current settings of the machine. When in this case the **“PLAY”** key (5) is pressed, the default sampling frequency of the machine will be momentarily changed to the new selected sampling frequency and the playback starts. If the **“STOP”** (4) key is not pressed at the end of the playback of this selected index, the playback continues on the next index that has the same sampling frequency as the previous selected index. In this case, once the **“STOP”** (4) key is pressed or the playback of the last found index with the same sampling frequency is ended, the machine will after a moment return to its default sampling frequency setting.

During the period that the **“DIRECTORY”** is on the display, all function keys **“PLAY”**, **“STOP”**, **“FWD”** and **“RWD”** (3,4,5 &6) are active.

If the **“RECORD”** button (2) is pressed, the display returns to the main screen and the recording starts.

### 14.1.1 HORIZONTAL SCROLLING.

Use the "LEFT" (10) and "RIGHT" (12) "ARROW" keys.

Selected file No: 002  
Current position: 1:30

File No 001, length 1minute 25 seconds, recorded March 12, 2000

End of list

Remaining time on the card at the selected compression

File No	Length	Date	Time
001	1:25	12. 03. 00	00
▶ 002	3:48	13. 03. 00	00
003	4:24	13. 03. 00	00
End	48:32		

File No	Length	Date	Time
001	0:00	12. 03. 00	00
002	1:25	12. 03. 00	00
▶ 003	3:48	13. 03. 00	00
004	4:24	13. 03. 00	00
End	48:32		

File No	Length	Date	Time
001	12. 03. 00	10: 41	
002	12. 03. 00	10: 55	
▶ 003	13. 03. 00	11: 25	
004	13. 03. 00	14: 19	
End	48:32		

File No	Length	Date	Time	Format
001				PCM 48k 16b st.
002				MPEG 192 / 48 st.
▶ 003				MPEG 128 / 24 st.
004				MPEG 192 / 32
End	48:32			

The display shows the length, the date of recording, the time at the record start and the type of file format.

### 14.1.2 VERTICAL SCROLLING.

File No	Length	Date	Time
001	0:00	12. 03. 00	00
002	1:25	12. 03. 00	00
▶ 003	3:48	13. 03. 00	00
004	4:24	13. 03. 00	00
End	48:32		

File No	Length	Date	Time
001	0:00	12. 03. 00	00
002	1:25	12. 03. 00	00
003	3:48	13. 03. 00	00
▶ 004	4:24	13. 03. 00	00
End	48:32		

Pushing the "UP" (9) or "DOWN" (11) "ARROW" keys makes the vertical scrolling.

### 14.1.3 QUIT DIRECTORY.

To escape from the "DIRECTORY", press the "CENTER" button (13) once followed by the "RIGHT" arrow key (12). The display returns to "STATUS" display.

File No	Length	Date	Time
001	0:00	12. 03. 00	00
002	1:25	12. 03. 00	00
▶ 003	3:48	13. 03. 00	00
004	4:24	13. 03. 00	00
End	48:32		

▶ Quit directory  
Edit index

File No	Length	Date	Time
002	0:00		
3 Index R: 4:08:26			

## 14.1.4 EDIT INDEX.

003	0:00		
007	0:00	12 . 03 . 00	
008	1:25	12 . 03 . 00	
▶ 009	1:23	13 . 03 . 00	
010	1:21	13 . 03 . 00	
End	48:32		

The editing option enables the cleaning-up of an index that contains periods of silence or noise and non useful sound. Once the editing is completed, the index will be saved as a new index. In the directory such edits will be marked with a "scissors" icon.

To edit an index, first select the index to be edited from the "DIRECTORY", press the "CENTER" key (13), select "EDIT INDEX" and press the "CENTER" key (13) again.

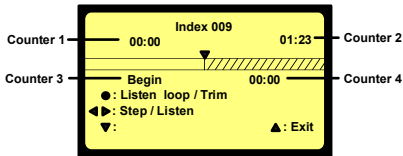

Counter 1 indicates the play position inside the edited index.

Counter 2 indicates the full length of the edited index.

Counter 3 indicates the reel play position from the start of the original index.

Counter 4 indicates only the position of each cut from the original index.

In this example, index 009 is selected and is shown as a tape. All edit commands are executed as shown in the picture by the "LEFT" (10), "RIGHT" (12), "UP" (9), "DOWN" (11) and "CENTER" (13) keys.

In addition, in the edit mode, the standard keys "REWIND" (3), "STOP" (4), "PLAY" (5) and "FORWARD" (6) act in the same way as for the standard play mode. The "REWIND" (3) as well as the "FORWARD" (6) key permits to skip from one cut position to another.

If markers were already present on the index, they will be shown as cut positions on the tape.

## PLACING CUTS

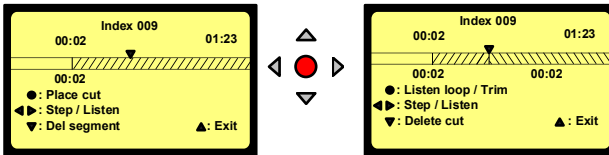

Example: Index 009 played back for 2 seconds and a first cut position was made.

This can be made in 2 different ways. The first possibility is to "drop" them on the fly. Push the "PLAY" key (5) and press the "CENTER" key (13) every time a cut position must be set.

The second possibility is to press and hold the "RIGHT" key (12). The machine goes in play mode until the key is released. If the "LEFT" key (10) is pressed and hold, the machine goes in play reverse. Once the key released, press the "CENTER" key (13) to show a cut position.

## DELETING A CUT POSITION

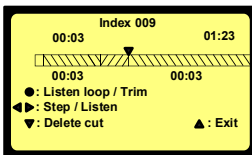

Example: A second cut position was set at 3 seconds "DELETE CUT" appears on the screen.

If a cut position needs to be removed, it can be done in 2 ways. The first is to use the skip function with the "REWIND" (12) or "FORWARD" (10) key until the cut position is found and press the "DELETE CUT" key. The second one is by using the "LEFT" (10) or "RIGHT" (12) key kept pressed to approach the cut line to the play head followed by a step by step approach until the counter 4 indicates the position. Once the positioning is reached, press the "DOWN" key (11) to delete the cut.

## DELETING A SEGMENT

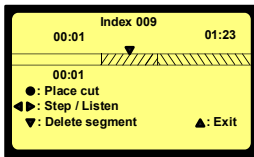

Example: Index 009 was rewound for 1 second. The play position sits between the start position and the first cut position. **"DELETE SEGMENT"** appears on the screen

When pressing the **"DOWN"** key (11), the segment from the beginning until the 2 seconds point will be deleted.

## UNDO A CUT OUT

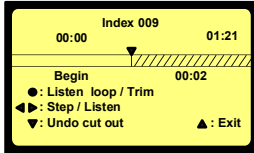

Example: The segment from the beginning until 2 seconds is cut out. **"UNDO CUT OUT"** appears on the screen.

If a wrong segment was cut out, it can be re-inserted by positioning the "tape" so that the play position is on top of the cut position. This can be done in 2 ways. The first is to use the skip function with the **"REWIND"** (3) or **"FORWARD"** (6) key until the cut position is found. The second is by using the **"LEFT"** (10) or **"RIGHT"** (12) key kept pressed to approach the cut line to the play head followed by a step by step approach until the counter 4 indicates the position. Once the positioning is reached, press the **"DOWN"** key (11) to undo the cut out.

## TRIMMING CUTS

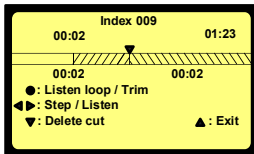

Example: The first cut position is placed below the play position indicator. **"LISTEN LOOP/TRIM"** appears on the screen

Once the first cut position is made and the playback position sits on that cut position, press the **"CENTER"** key (13) once again and the editor starts a loop playback around the cut position. It starts playing 1second before the cut position and continues to play 1 second after the cut position.

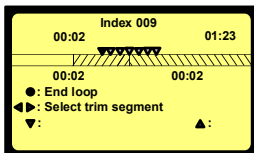

Example: The play starts from 1 second until 3 seconds **"SELECT TRIM SEGMENT"** appears on the screen.

During the playback loop, the **"LEFT"** (10) or **"RIGHT"** (12) key permits to select the left or right segment to be trimmed. This means that the length of the selected left or right segment can be reduced.

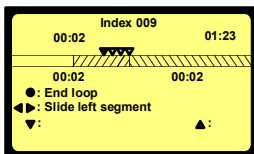

Example: The left segment is selected. **"SLIDE LEFT SEGMENT"** appears on the screen.

In this case, the playback loop starts 1 second before the cut position and ends at the cut position. The length of the left segment can now be reduced by pressing and holding the “LEFT” key (10) or step by step by clicking the same key. In this case the audio will be reduced with a size between 50 and 100 ms. If the reduction was too great, it can be increased again back to the original length by pressing the “RIGHT” key (12).

## EXIT THE EDITOR

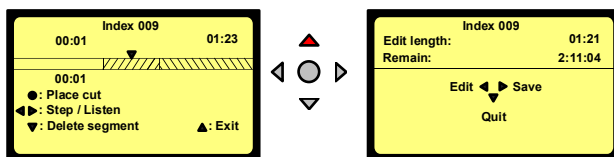

To exit the editor, press the “UP” key (9).

The display permits to select “SAVE” (12), “QUIT” (11) or return to “EDIT” (10).

Pressing “SAVE” (12) shows the next displays

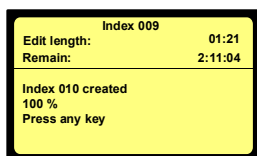
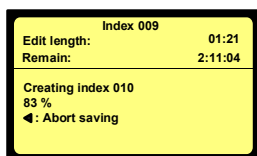

The saving started and it is still possible to “ABORT” (10).

Once the right display appears, the new file was created. The created index number is always the highest existing index number in the directory +1.

**Note:** If the directory is full (999 indexes) a warning will appear at the start of the editing.

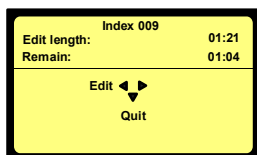

If the remaining time on the card is shorter than the selected index length, a new window will appear but without the “SAVE” possibility. It is up to the user if he thinks that once the index is edited, the size will be smaller than the remaining time. In this case the “EDIT” can be selected.

In this example, the full length of the original index is 1 minute 21 seconds, but only 1 minute and 4 seconds remaining time is left, so the final edit must be smaller than this.

Maximum 100 cut positions can be entered on 1 index.

During editing the “POWER” key (1) is disabled. If during editing, the machine switches off due to low battery voltage, the new index will not be saved. If during saving the edited index, the machine switches off due to low battery voltage, the saving will be aborted.

During editing the “AUTO POWER OFF” function is also disabled as long as the index has not been saved. In the case that the saving was aborted, the “AUTO POWER OFF” will stay disabled. In the case the file was saved correctly, “AUTO POWER OFF” becomes enabled.

#### 14.1.5 DELETE.

Any file or index from the directory can be deleted without influencing other takes. To do so, in the directory, select the index to be erased, press the “CENTER” key (13), select “Delete index” and confirm.

#### 14.1.6 DELETE TO END.

Erase the selected index and all indexes after until the end of the card.

#### 14.1.7 RENUMBER.

Permits after deleting indexe(s) to renumber the files from the selected file until the end of the card.

#### 14.1.8 RENUMBER ALL.

Permits after deleting indexe(s) to renumber all the files from file 1 until the end of the card.

#### 14.1.9 DELETE ALL MARKS.

Permits to remove all markers from the selected index made during record or play.

#### 14.2 LOUDSPEAKER.

This switches “ON” or “OFF” the internal loudspeaker.

**NOTE:** The internal loudspeaker can only be used in the playback mode.

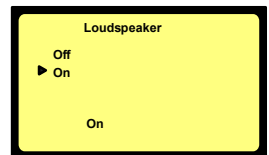

#### 14.3 TOOLS.

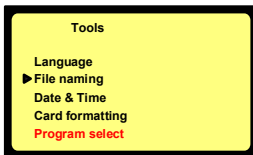

Several sub-menus are available.

**NOTE:** If option #1 is not installed, “PROGRAM SELECT” will not appear.

#### 14.3.1 LANGUAGE.



The “LANGUAGE” sub-menu allows selection of the desired language for all text appearing on the display of the machine.

#### 14.3.2 FILE NAMING.

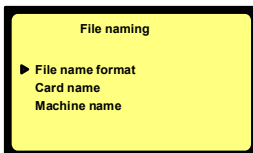

The “FILE NAMING” sub-menu determines the way the name of the recordings will be defined and stored on the card. It is possible to select the “MACHINE NAME” or the “CARD NAME” combined with “DATE” or “TIME”.

### 14.3.2.1 FILE NAME FORMAT.

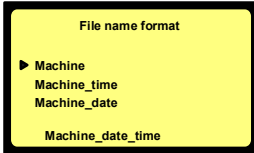

Several combinations are available:

In the following examples, the machine name is "ABC" and the card name is "DEF".

- **Machine:** Only the machine name followed by the index number (Ex. ABC001).
- **Machine\_time:** The machine name followed by the time and the index number (ex. ABC182035\_002).
- **Machine\_date:** The machine name followed by the date and the index number (ex. ABC20050701\_003).
- **Machine\_date\_time:** The machine name followed by the date, time and the index number (ex. ABC20050701\_182035\_004)
- **Card:** Only the card name followed by the index number (Ex. DEF005).
- **Card\_time:** The card name followed by the time and the index number (Ex. DEF182540\_006).
- **Card\_date:** The card name followed by the date and the index number (Ex. DEF20050701\_007).
- **Card\_date\_time:** The card name followed by the date, time and the index number (ex. DEF20050701\_182035\_008)

### 14.3.2.2 CARD NAME.

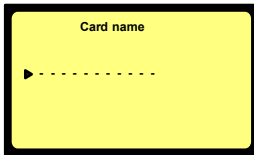

The "**CARD NAME**" corresponds to the volume label. The "**CARD NAME**" menu permits to add up to 11 characters or numbers to the file name before the index number. The index number in the file name is the last 3 digits and is automatically incremented by the machine (nnn: min. 001, max. 999). To enter the card name, press the "**CENTER**" (13) key once and the first character starts blinking. By using the "**UP**" (9) or "**DOWN**" (11) arrow key, select the corresponding character or number. Pressing the "**RIGHT**" (12) arrow key or the "**CENTER**" (13) key selects the next character position. Once the eleventh character is selected press first the "**CENTER**" (13) key or "**RIGHT**" (12) key to validate the last character position. To escape from the menu, press the "**LEFT**" (10) key. If less than 11 characters are used, select the symbol ↵.

**Note:** If the card is reformatted, the card name must be re-introduced.

### 14.3.2.3 MACHINE NAME.

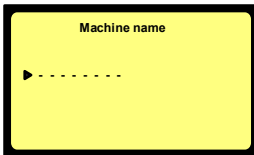

The "**MACHINE NAME**" menu permits to add up to 8 characters or numbers to the file name before the index number. To do so, press the "**CENTER**" (13) key once and the first character starts blinking. By using the "**UP**" (9) or "**DOWN**" (11) arrow key, select the corresponding character or number. Pressing the "**RIGHT**" (12) arrow key or the "**CENTER**" (13) key selects the next character position. Once the eighth character is selected press first the "**CENTER**" (13) key or "**RIGHT**" (12) key to validate the last character position. To escape from the menu, press the "**LEFT**" (10) key. If less than 8 characters are used, select the symbol ↵.

### 14.3.3 DATE AND TIME.

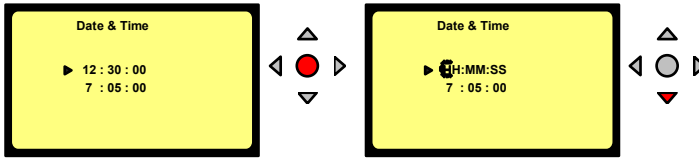

Selecting “DATE & TIME” gives access to change the time and date of the real time clock. Once the “CENTER” button (13) is pressed, the first digit starts blinking. The number can be modified by pushing the “UP” or “DOWN” (9 or 11) keys. Pressing the “RIGHT” arrow key (12) jumps to the next digit. Once the last number is introduced, the clock starts running. (Hours, Hours, Minutes, Minutes, Seconds, Seconds)

Introducing the date uses the same procedure.

Once the last number is introduced, the date is memorized.

To escape from the sub-menu, press the “LEFT” (10) key once.

### 14.3.4 CARD FORMATTING.

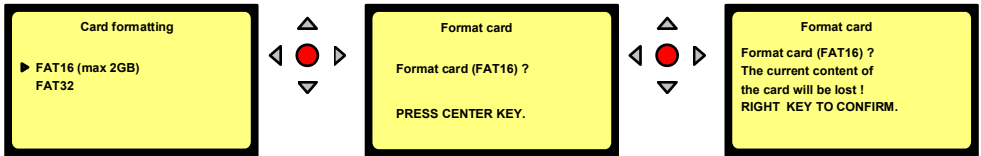

Select “FAT 16” or “FAT 32” and execute by pressing the “CENTER” arrow key (12) and confirm.

Once the formatting is finished, the display returns to the previous menu.

To escape from the sub-menu, press the “LEFT” (10) key once.

**Important:** It is recommended to format the ATA cards or Compact flash cards on the machine and NOT on a PC. The FAT 16 format is limiting the size of a card to maximum 2 GB. Example: A 4GB card formatted with the FAT 16 standard will show a useful capacity of only 2 GB.

The minimum card size for formatting in the FAT 32 standard is 150 MB.

If a card is formatted FAT 32, it will not be recognized anymore on the Ares-P II or Ares-BB.

### 14.3.5 BATTERY TYPE.

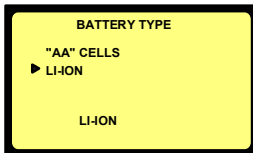

This menu allows selection of the type of battery connected to the Ares-BB<sup>+</sup>.

For dry cells, Ni-mH or Ni-Cd, fitted in the NB-BB box select the mode “AA” cells. For the Lithium-Ion pack NB-LIB, select “Li-ion”. If the “Li-ion” selection is made when using the NB-BB pack, then the machine will shut down before the cells are completely exhausted. If however

“AA” cells is selected but a Lithium Ion pack is used, then during record, the machine may suddenly turn off as the pack will be exhausted and go into its internal safety protection mode before the machine shuts down.

### 14.3.6 PROGRAM SELECT.

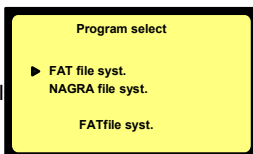

The program select permits to swap between the 2 recording modes “FAT” mode (ARES-BB<sup>+</sup>) or “NFS” mode (Ares-P or RCX220).

**NOTE:** This sub menu does not appear if software option #1 is not installed.  
To escape from the sub-menu, press the “LEFT” key (10) once.

### 14.3.7 CONTRAST.

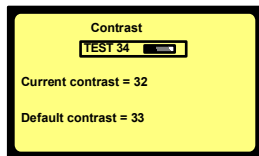

This menu permits to adjust the contrast of the display. Pressing the “UP” (9) or “DOWN” (11) key changes the current contrast. Pressing the “CENTER” key (13) stores the contrast settings as a default value at power on.

To escape from the sub-menu, press the “LEFT” key (10) once.

### 14.3.8 AUTO POWER OFF.

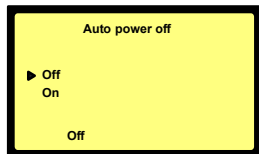

If “ON” is selected and the machine is left in the “STOP” mode for 10 minutes, it will automatically switch off. During the last 14 seconds of that period, the beep sounds every second. When any key is pressed, the power counter will be reset.

To disable the auto power off, select in the sub-menu “OFF” or if it is only for a single power on, press and hold the “EXECUTE” key (13)

while switching on the machine.

In the case that the machine is turned on with the auto power disabled, the message “NO AUTO POWER OFF” appears during a few seconds.

### 14.3.9 VERSION.

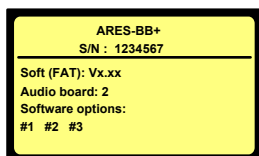

Selecting the “VERSION” sub-menu shows the serial number of the recorder as well as the current version of the software installed. The version shown in this picture corresponds to the version for the “FAT” mode. Turning on the machine in the “NFS” mode will show the “NFS” version.

To escape from the sub-menu, press the “LEFT” key (10) once.

**NOTE:** All machines are equipped with “AUDIO BOARD: 2”  
#1 means that the MPEG option is installed.  
#2 means that the RCX220 emulation option is installed.  
#3 means that the EDIT option is installed.

### 14.4 TEMPLATES.

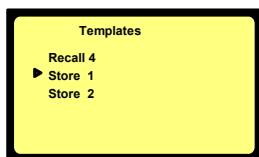

The Ares-BB+ can store and recall 4 different templates.

To have an overview of the different sub-menu settings that can be stored, refer to the menu tree at the end of this manual. Only menu settings with a red square against it can be stored. 

To use a template, setup the machine as required, then go to “TEMPLATES”, select “STORE 1” and press the execute key (13). The message “DONE” will appear. If now any changes were made in the setup, you can go to “RECALL 1” and press the execute key once again. This returns the machine to the settings stored in template 1.

## 14.5 SETTINGS MENU.

The settings menu gives access to several sub-menus.

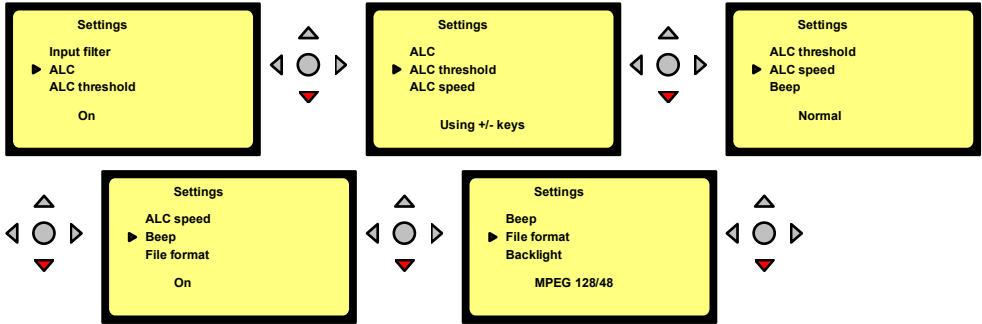

The current setting of each is always shown at the bottom of the display.

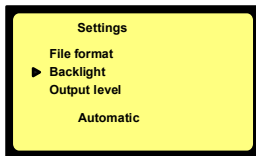

### 14.5.1 INPUT FILTER.

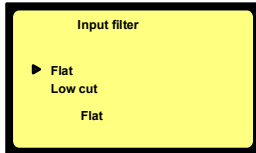

Two possibilities are available: “**FLAT**” or “**LOW CUT**”.

When “**LOW CUT**” is selected, on the main display, the text  will appear next to the battery status.

### 14.5.2 ALC.

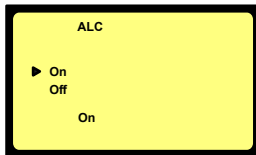

From this sub-menu, the “**ALC**” can be switched “**ON**” or “**OFF**”.

It is highly recommended to switch on the “**LOW CUT**” filter if “**ALC**” is turned ON.

### 14.5.3 ALC THRESHOLD.

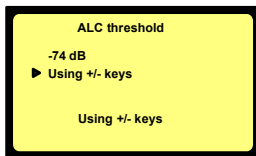

The “**THRESHOLD**” can be adjusted from  $-104$  dB to  $-74$  dB.

In this case the “+”key (8) and the “-”key (7) are disabled. If “**USING +/- KEYS**” is selected, the “+”key (8) and “-”key (7) are enabled during “**STOP**” and “**RECORD**” mode, which allows the “**THRESHOLD**” level to be adjusted without returning in the “**SETTINGS**” menu.

#### 14.5.4 ALC REACTION SPEED.

The “**ALC SPEED**” can be set to a “**FAST**”, “**NORMAL**” or “**SLOW**” reaction time.

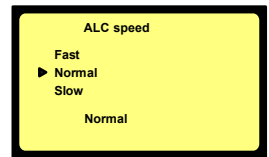

#### 14.5.5 INPUT LEVEL.

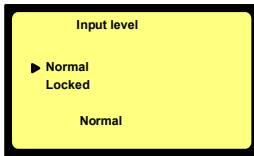

The “**INPUT LEVEL**” can be set to “**NORMAL**”, in this case the input level sensitivity is adjusted by the +/- keys (8 & 7). If the “**INPUT LEVEL**” is set to “**LOCKED**”, the input sensitivity will be fixed at the last value prior to selecting “**LOCKED**”. If in this mode adjustment is attempted, a “closed padlock” symbol appears next to the level indicator. Beware that this setting has no effect if the “**ALC**” mode is “**ON**”.

#### 14.5.6 BEEP.

The beep signal is only available at the output and is not recorded. It can be switched “**ON**” or “**OFF**”.

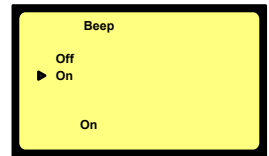

#### 14.5.7 FILE FORMAT.

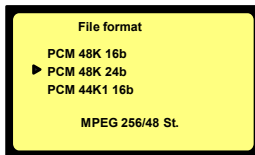

The Ares-BB+ without any soft option can only record in a linear mode (not compressed). If the soft option #1 is installed it includes also the selection of MPEG compression up to 384kb/s. The selection of “**24b**” means that the audio is recorded through a 20 bit A/D converter and the data format of the file is written in 24 bits.

#### 14.5.8 BACKLIGHT.

The backlight can be set to always “**OFF**”, always “**ON**” or “**AUTOMATIC**”. In the “**AUTOMATIC**” mode, the backlight turns on for 30 seconds, each time a key is pressed.

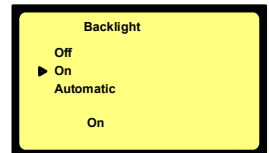

#### 14.5.9 OUTPUT MODE.

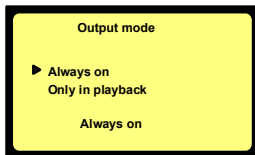

This sub-menu permits to turn on or off the sound to the output connector in the case that a little speaker is used instead of a headphone. “**ALWAYS**” means that the output sound is always present. “**ONLY IN PLAYBACK**” means that the output sound is present only during playback but not present in the record mode or EE mode.

#### 14.5.10 OUTPUT LEVEL.

The “**CURRENT LEVEL**” corresponds to the setting before entering the sub-menu. To modify this level, press the “**UP**” or “**DOWN**” keys (9 or 11). The “**DEFAULT LEVEL**” is the level that has been saved in the memory. To modify the “**DEFAULT LEVEL**” to the value of the “**CURRENT LEVEL**”, press the “**CENTER**” key (13). The default value will be remembered even if the unit loses power.

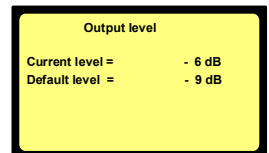

Every time that the output level was modified during playback and afterwards a new record is started, the current value will be reset to the default level.

### 14.5.11 MS DECODER.

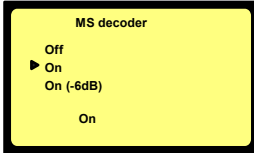

The “**MS DECODER**” sub menu appears only in the “**FAT**” mode and permits to switch on or of the MS decoding for the headphones. The “**M**” channel corresponds to the left channel input, the “**S**” channel corresponds to the right channel input. The “**ON (-6 dB)**” is to reduce the saturating danger in case that the recording is made with high input levels.

### 14.5.12 START / STOP CONFIGURATION.

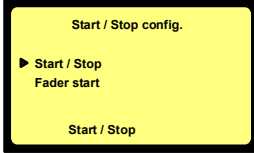

When “**Record/New index**” is selected, the machine can be put into record via the 3.5 mm “**Start /Stop**” input. The first time the input is momentarily shorted out, the machine starts recording, the next time, it starts a new recording (seamless). When “**Record/Stop**” is selected, the machine starts recording at a momentarily short-circuit on the “**Start /Stop**” input, and stops recording

on the next short-circuit.

If “**Record/Mark**” is selected, the machine starts recording if the input is briefly shorted out, afterwards every time the input is briefly shorted, it adds a marker.

If “**Mark (Rec & Play)**” is selected, when briefly shorted out, it will only add markers.

When “**Start / Stop**” is selected, the machine starts recording if the input is shorted and stops recording if the input is oopen.

When “**Fader start**” is selected, the machine can be put in playback. Short-circuit the input will select the play mode.

Mode/ Function	1 <sup>st</sup> contact	2 <sup>nd</sup> contact	Break contact
Rec / New index	Record	Record new index	x
Rec / Stop	Record	Stop	x
Rec / Mark	Record	Insert marker	x
Mark / (Rec Play)	Insert marker	Insert marker	x
Start / Stop	Record	Record	Stop
Fader start	Playback	Playback	Stop

### 14.5.13 AUTOMATIC SKIP.

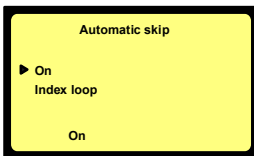

When “**On**”, and pushing playback from the directory or the main menu, the playback will continue non-stop until the end of the card.

When “**Index loop**” is chosen, only the selected index will be played back in loop mode. To select another index use the skip keys (3) & (6). To playback the same file, press the “**REWIND**” key (3) shortly and push play again.

### 14.5.14 RED LED LEVEL.



As standard, the red led on the modulometer turns on when the level reaches minimum 0 dB. Four different reference selections can be made. Beware that if the +9 dB is selected, the red led indicates overload.

## 14.6 AUTO RECORD.

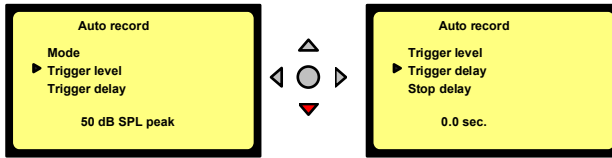

The “**AUTO RECORD**” menu permits to turn on or off the auto record mode. This mode of recording permits to start a recording automatically depending on the settings of the different parameters described below. Once the parameters set, put the machine in the record mode. The recording will start once the requested level and length of any incoming sound is obtained.

The “**TRIGGER LEVEL**” sub-menu permits to adjust the level detection to start the recording and can be set in steps of 10 dB from 50 dB SPL peak to 120 dB SPL peak.

The “**TRIGGER DELAY**” menu permits to adjust the continuous duration or length of the sound level before the recording starts. It can be set from 0.0 seconds to 1 second. Example: if you clap your hands a single time and the start delay is set to 0.1 second, the recording will not start, as the handclap was shorter than 0.1 seconds.

The “**STOP DELAY**” permits to adjust the duration of recording once the sound level drops below the threshold level and can be set from 5 seconds up to 15 minutes or non-stop. Once the delay is passed, the machine will return to the waiting position ready for the next recording

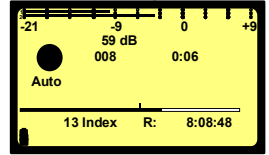
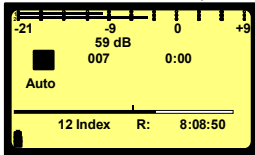

The left picture shows the machine ready to record automatically. The right picture shows the machine in the record mode.

The Ares-BB+ can also be stopped manually by pressing the Stop button (4).

## 14.7 INPUT.

This menu gives access to the selection of the microphone type (routing, Mono or Stereo) as well as the 48V power supply.

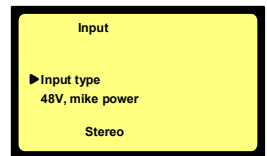

### 14.7.1 INPUT TYPE.

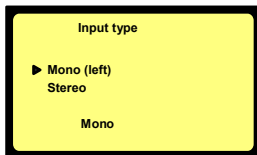



Mike type selection	Mono	Mono	Stereo	Stereo
File format selection	Mono	Stereo	Mono	Stereo
1 mike connected (L)	L only	L = R		
2 mikes connected			L + R -3dB	L & R

If “**STEREO**” is selected and a stereo pair of microphones is connected and the “**FILE FORMAT**” is set to a mono recording, both channels will be mixed and reduced by 3 dB before they are recorded as a mono channel.

If “**MONO**” is selected and a mono microphone is connected to the left input and the “**FILE FORMAT**” is set to a stereo recording, the left and right channel will be identical.

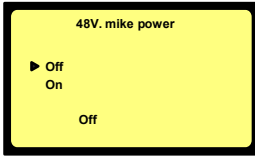
## 14.7.2 48V MIKE POWER.



If Phantom microphones are used the 48V must be turned on. This selection needs to be confirmed by pressing the right arrow key. On the main display, the text  will appear next to the battery status.

## 15 LOCKING THE SETTINGS.

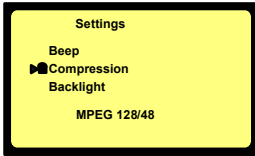

By pressing a certain combination of keys when turning on the machine, the settings can then be locked step-by-step. This is to prevent, the user changing the settings inadvertently or otherwise. To obtain the combination code, contact your local **NAGRA** dealer.

Almost all sub-menus can be locked by pressing the **"STOP"** button or unlocked by pressing the **"PLAY"** button. When the sub-menu has been locked, a closed padlock appears in front of the selected sub-menu. When the sub-menu has been unlocked, the closed padlock disappears. To remove the password, switch off and on again the machine.

## 16 LOCKING THE KEYPAD.

During record or playback the keyboard can be locked by setting the keypad switch (15) to ON. To unlock the keyboard, set the same switch back to OFF. When the keypad is locked, the message **"KEYPAD LOCK"** appears on the display.

## 17 AUTO POWER OFF

When the machine is left in the **"STOP"** mode for 10 minutes, it will automatically switch off. During the last 14 seconds of that period, the beep sounds every second. When any key is pressed, the power counter will be reset.

To disable the auto power off, **from the power off status**, press and hold the centre key while pressing the power key.

In the case that the machine is turned on with the auto power disabled, the message **"NO AUTO POWER OFF"** appears during a few seconds.

## 18 MESSAGES

"WRONG USB VERSION"	DSP and USB software versions are incompatible
"CARD FULL"	No more memory available on the card
"OPEN WRITE ERROR"	Defective card or card error
"WRITE ERROR"	Defective card or card error
"READ ERROR"	Defective card or card error
"CARD TOO SLOW"	Depending from the selected file format, some cards do not accept a high recording bit rate
"DIRECTORY FULL"	Index #999 exist already
"CARD NEARLY FULL"	60 seconds recording time left on the card
"KEYPAD LOCKED"	The full keypad is locked
"AUTO POWER OFF"	The machine will switch of in the next 15 seconds
"LOW BATTERY"	The battery voltage has dropped too low
"NO AUTO POWER OFF"	Auto power off has been disabled

"INVALID CARD"	The card is not recognized by the machine
"NO CARD"	No card inserted in the slot
"UNKNOWN FORMAT"	The card is recognized but not the type of format
"DIR UNUSABLE"	The "ARESP" folder cannot be created Example: an ARESP file name was already present
"CARD READING..."	Appears during the directory reading
"CARD BUSY..."	Appears when the card is busy Example: delete to end or renumbering
"USB MODE"	The card is accessed via USB
"AUTO REC. LEVEL ERROR"	The input gain is not suitable versus the record trigger level
"UNABLE TO CREATE INDEX"	During saving in edit mode
"ABORTED"	During saving in edit mode
"FAILED"	Example: During mark(s) erase
"THE CARD IS IN USE"	An action was requested without being in the "STOP" mode
"NO INDEX SELECTED"	Example: Trying to delete an index without having selected one
"NO MARKS IN INDEX NNN"	During mark(s) erase
"MARKS IN INDEX NNN CANNOT BE DELETED"	Can happen if the marks are added using an external editor.

## 19 SOFTWARE UPDATE

A small black 6 pin connector is located just under the flashcard. A special adapter "**NP-PCA**" is needed to connect the machine to the RS232 connector of the PC or laptop. When new software from NAGRA becomes available, it can be delivered by Email or it can be downloaded from the NAGRA web site. By using the PC software called "**PuserLoader**" the machine can be updated with the new software version. This takes about 2 to 3 minutes.

# 20 MENU TREE ARES-BB<sup>+</sup>

## ARES-BB<sup>+</sup> (FAT MODE) INCLUDING SOFTWARE OPTION #1 AND #3

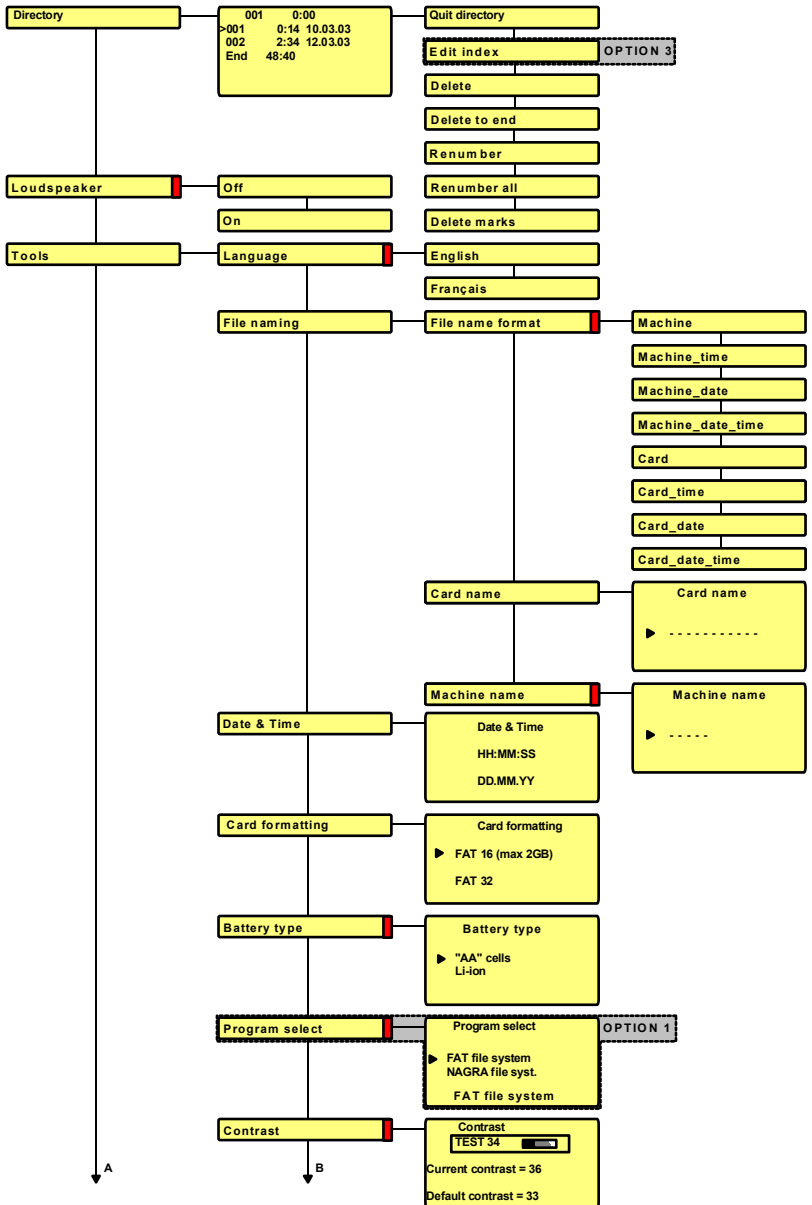

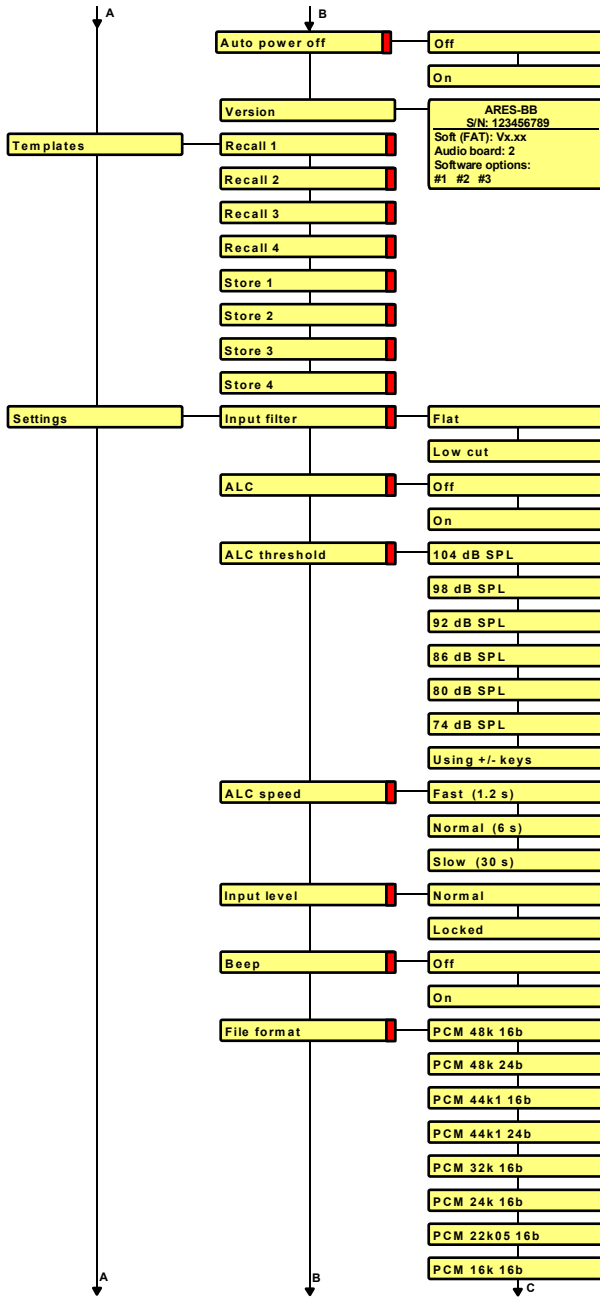

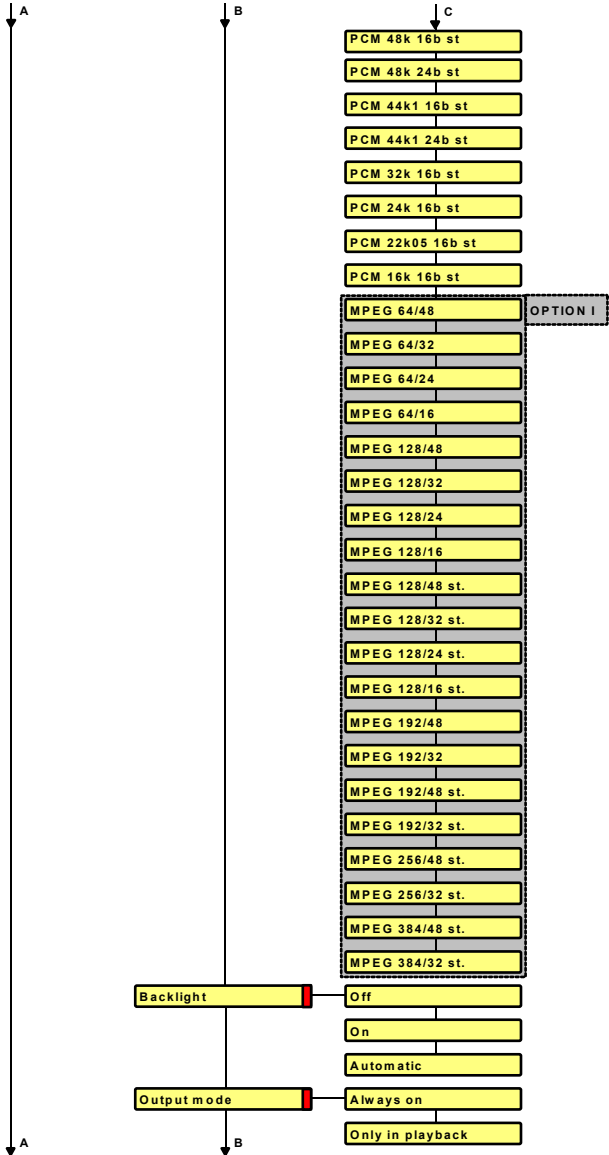

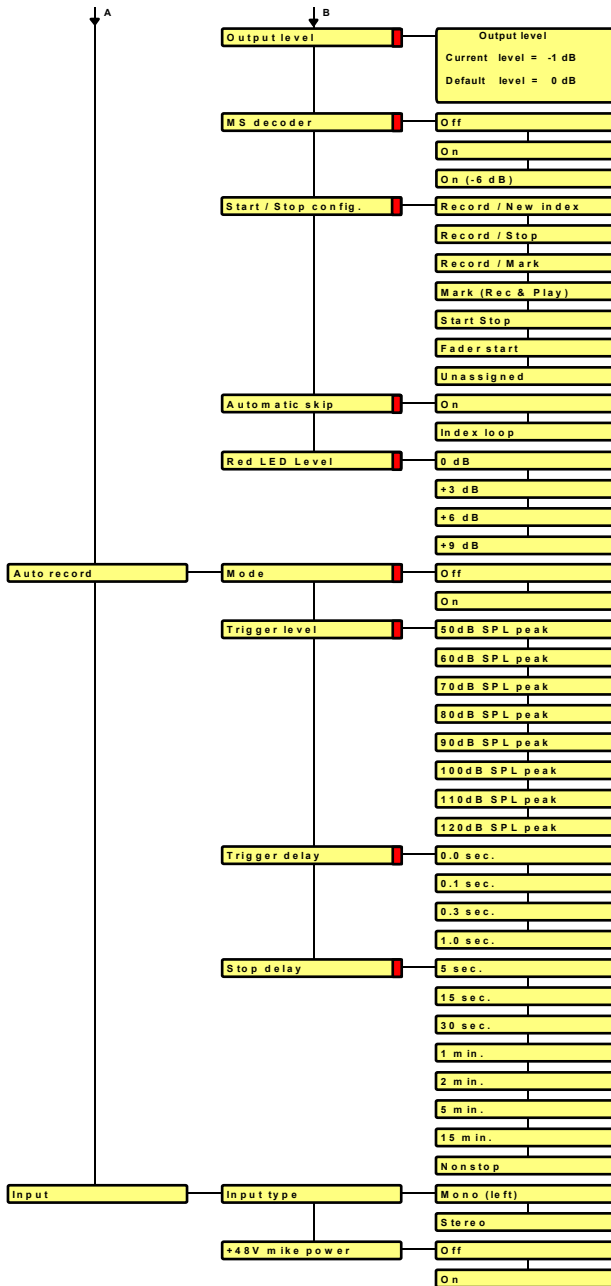

## 21 INPUTS, OUTPUTS

### 21.1 INPUT SIDE



Mic. / Line Inputs	2 XLR connectors
Microphone Powering	48 V Phantom via menus
Microphone Sensitivity	10 mV, 2mV Pa switchable
Sensitivity	From 2 mV to 10 mV for 0 dB recording
Line Input	Symmetrical transformerless
Line Input Sensitivity	0.44 V to 1.4 V for 0 dB recording
External power	XLR connector 4 pole or DC connector
Green led	External power presence indicator
Yellow led	Charge indicator
USB connector	USB 1.1

### 21.2 OUTPUT SIDE



Headphone	Jack 6.3 mm stereo connector
Potentiometer	Adjust the headphone output level
Line Output	2 XLR connectors, symmetrical transformerless
Start/Stop remote	Mini jack mono 3.5 mm
Software update	Small 6 pin connector for NP-PCA adapter
THD at 1 kHz	0.1 %
Frequency response	30 Hz – 20 kHz (-3 dB in EE mode)
Total dynamic range	80 dB

## 22 ARES-BB<sup>+</sup> PC SOFTWARE & INSTALLATION (NFS MODE)

These programs add several features when the ARES-BB<sup>+</sup> is connected to the USB port of a PC or if the flashcard from the ARES-BB<sup>+</sup> is inserted in a PC PCMCIA slot:

Display the directory of the flash card

Playback of the recorded files

Import recorded files into the computer's hard disk

Edit the recorded files.

Insert the CD in your PC or laptop and follow the instructions.

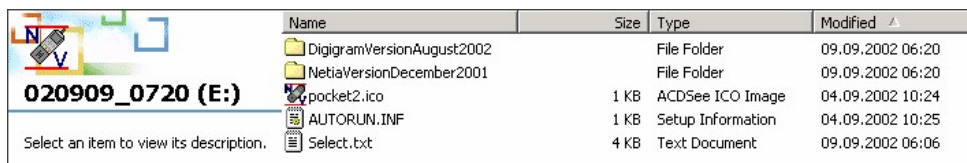

Name	Size	Type	Modified
DigigramVersionAugust2002		File Folder	09.09.2002 06:20
NetiaVersionDecember2001		File Folder	09.09.2002 06:20
pocket2.ico	1 KB	ACDSee ICO Image	04.09.2002 10:24
AUTORUN.INF	1 KB	Setup Information	04.09.2002 10:25
Select.txt	4 KB	Text Document	09.09.2002 06:06

### 22.1 ARES-BB<sup>+</sup> SOFTWARE, USING A PC PCMCIA SLOT (NFS MODE)

Carefully read the text file in the root directory before any installation.

From explorer, double click the NetiaVersion folder followed by the AresImport folder.

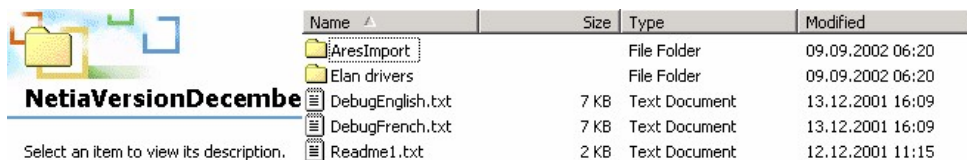

Name	Size	Type	Modified
AresImport		File Folder	09.09.2002 06:20
Elan drivers		File Folder	09.09.2002 06:20
DebugEnglish.txt	7 KB	Text Document	13.12.2001 16:09
DebugFrench.txt	7 KB	Text Document	13.12.2001 16:09
Readme1.txt	2 KB	Text Document	12.12.2001 11:15

Double click "SETUP.EXE" file to start the installation.

If the PCMCIA slot is based on an ISA or PCI bus or built-in to a laptop, the Elan drivers need also to be installed. If the PCMCIA slot is connected via SCSI, the Elan drivers may not be installed.

### 22.2 ARES-BB<sup>+</sup> SOFTWARE, USING A PC USB PORT (NFS MODE)

This only works if both software options I & II are installed on the Ares-BB<sup>+</sup>

Carefully read the text file in the root directory before any installation.

From explorer, double click the DigigramVersion folder followed by setup.exe.

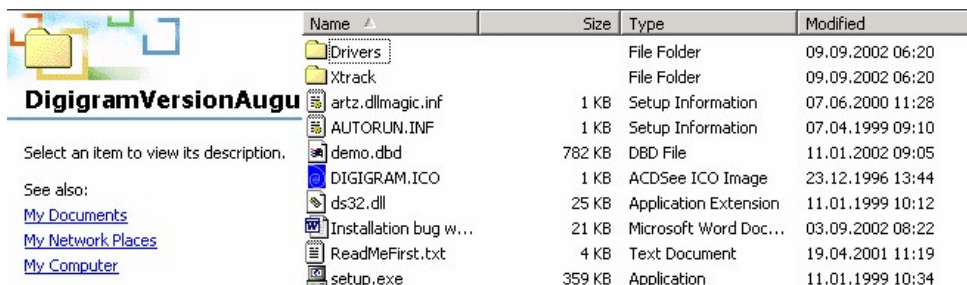

Name	Size	Type	Modified
Drivers		File Folder	09.09.2002 06:20
Xtrack		File Folder	09.09.2002 06:20
artz.dllmagic.inf	1 KB	Setup Information	07.06.2000 11:28
AUTORUN.INF	1 KB	Setup Information	07.04.1999 09:10
demo.dbd	782 KB	DBD File	11.01.2002 09:05
DIGIGRAM.ICO	1 KB	ACDSee ICO Image	23.12.1996 13:44
ds32.dll	25 KB	Application Extension	11.01.1999 10:12
Installation bug w...	21 KB	Microsoft Word Doc...	03.09.2002 08:22
ReadMeFirst.txt	4 KB	Text Document	19.04.2001 11:19
setup.exe	359 KB	Application	11.01.1999 10:34

### AresImport:

AresImport permits to read the directory from the flash card as well as playback and or import and conversion.

### RCXLoad:

Display the files located on the memory card with their characteristics (date, duration, encoding format) in an MS explorer fashion.

Playing back a selected file, using the ARES-BB+ audio output or the local PC sound card.

Using Drag and Drop, import one or several files with format conversion to MPEG Layer 2 or PCM format.

### XtrackLE (a Limited Edition of Xtrack):

Uses the physical I/O of the RCX220 as well as any other standard device.

Offers two fully independent mono or stereo tracks where records can be uploaded via RCXload.

Provides you with of a complete set of tools to cut, copy, paste, trim any portion of a track, as well as level editing functions such as fade in and fade out.

Once the edit finished, it can be processed into a single sound file (**MPEG** or **PCM**) with automatic sampling frequency and bit rate conversion.

To obtain full multi-track editing capabilities including mp3 export, the full version of Xtrack software can be purchased from Digigram.

## 23 ARES-BB<sup>+</sup> PC DRIVERS & INSTALLATION (FAT MODE)

Turn on the Ares-BB<sup>+</sup> and connect it via the USB cable to the PC or Mac. After a moment, the new device will be detected as an external removable hard drive.

**IMPORTANT: for Windows 98 SE users; connect the Ares-BB<sup>+</sup> (FAT mode) to the PC. Once Windows asks for the USB drivers to be installed, specify the way to the CDR "Win98SeUsbDrivers" folder.**

The following pictures are an example on PC were the ARES-BB<sup>+</sup> is recognized as disk (F).

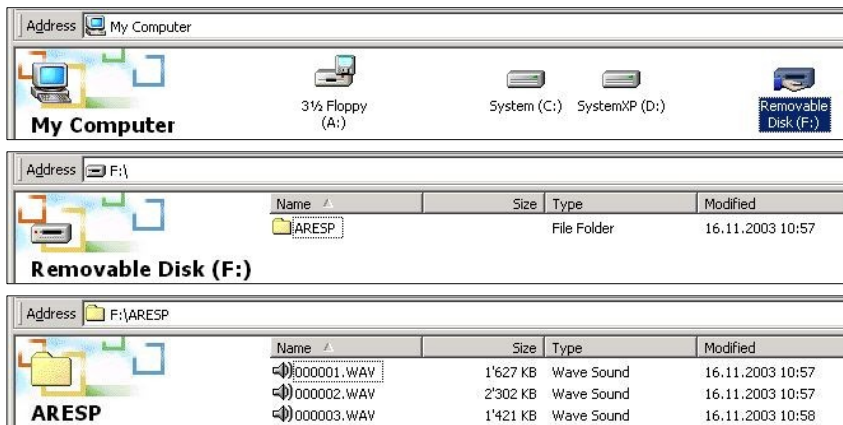

On PC, to remove the Ares-BB<sup>+</sup> from the USB connection, double click first the "Unplug or Eject Hardware" icon and stop the corresponding drive letter before removing the USB cable.



## 24 FLASH CARDS COMPATIBILITY.

**Note:** We have not tested all available cards and adapters on the market. Therefore we cannot guaranty the perfect operation in our machines. Cards and adapters supplied by Nagra are guaranteed to operate within the machine specifications.

**Formatting:** Do not format cards on PC but only on the Ares-BB<sup>+</sup>.

The following cards and adapters are used and tested by Nagra:

Compact flash:	ACE	64MB	FC064
	ACE	128MB	FFC128
	PRETEC	256MB	CFH256
	PRETEC	512MB	40x
	PRETEC	1GB	40x
Micro drive:	HITACHI	1GB	DSCM-11000
	IBM/HITACHI	4GB	13G1762
PCMCIA adapter	DATAFAB		TYPE I/II
	PRETEC		CF <sup>+</sup>
	IBM/HITACHI		13G1037

## 25 LANGUAGES

### Français

### English

### Max characters

Répertoire	Directory	max. 18 chars.
Haut-parleur	Loudspeaker	max. 18 chars.
Outils	Tools	max. 18 chars.
Modèle	Templates	max. 18 chars.
Paramètres	Settings	max. 18 chars.
Enreg. automatique	Auto record	max. 18 chars.
Entrées	Input	max. 18 chars.
Nom du fichier	File naming	max. 18 chars.
Date & Heure	Date & Time	max. 18 chars.
Formatage de carte	Card formatting	max. 18 chars.
Réparat. de format	Format repairing	max. 18 chars.
Type de batterie	Battery type	max. 18 chars.
Sél. de logiciel	Program select	max. 18 chars.
Contraste	Contrast	max. 18 chars.
Version	Version	max. 18 chars.
Filtre d'entrée	Input filter	max. 18 chars.
CAG (gain auto.)	ALC	max. 18 chars.
Seuil CAG	ALC threshold	max. 18 chars.
Vitesse CAG	ALC speed	max. 18 chars.
Bip	Beep	max. 18 chars.
Format de fichier	File format	max. 18 chars.
Compression	Compression	max. 18 chars.
Rétro-éclairage	Backlight	max. 18 chars.
Mode de sortie	Output mode	max. 18 chars.
Niveau de sortie	Output level	max. 18 chars.
Touche latérale	Side key	max. 18 chars.
Décodeur MS	MS decoder	max. 18 chars.
Saut automatique	Automatic skip	max. 18 chars.
Type d'entrée	Input type	max. 18 chars.
+48V micro	48V mike power	max. 18 chars.
Sortie	Quit directory	max. 18 chars.
Editer l'index	Edit index	max. 18 chars.
Effacer l'index	Delete index	max. 18 chars.
Effacer -> fin	Delete to end	max. 18 chars.
Renommer	ReNUMBER	max. 18 chars.
Renommer tout	ReNUMBER all	max. 18 chars.
Effacer marqueurs	Delete marks	max. 18 chars.

Titrage d'index	Index titling	max. 18 chars.
Charger 1	Recall 1	max. 18 chars.
Charger 2	Recall 2	max. 18 chars.
Charger 3	Recall 3	max. 18 chars.
Charger 4	Recall 4	max. 18 chars.
Sauvegarder 1	Store 1	max. 18 chars.
Sauvegarder 2	Store 2	max. 18 chars.
Sauvegarder 3	Store 3	max. 18 chars.
Sauvegarder 4	Store 4	max. 18 chars.
G722	G722	max. 18 chars.
PCM 48k 16b	PCM 48k 16b	max. 18 chars.
PCM 48k 24b	PCM 48k 24b	max. 18 chars.
PCM 44k1 16b	PCM 44k1 16b	max. 18 chars.
PCM 44k1 24b	PCM 44k1 24b	max. 18 chars.
PCM 32k 16b	PCM 32k 16b	max. 18 chars.
PCM 24k 16b	PCM 24k 16b	max. 18 chars.
PCM 22k05 16b	PCM 22k05 16b	max. 18 chars.
PCM 16k 16b	PCM 16k 16b	max. 18 chars.
PCM 48k 16b st	PCM 48k 16b st	max. 18 chars.
PCM 48k 24b st	PCM 48k 24b st	max. 18 chars.
PCM 44k1 16b st	PCM 44k1 16b st	max. 18 chars.
PCM 44k1 24b st	PCM 44k1 24b st	max. 18 chars.
PCM 32k 16b st	PCM 32k 16b st	max. 18 chars.
PCM 24k 16b st	PCM 24k 16b st	max. 18 chars.
PCM 22k05 16b st	PCM 22k05 16b st	max. 18 chars.
PCM 16k 16b st	PCM 16k 16b st	max. 18 chars.
MPEG 64/48	MPEG 64/48	max. 18 chars.
MPEG 64/32	MPEG 64/32	max. 18 chars.
MPEG 64/24	MPEG 64/24	max. 18 chars.
MPEG 64/16	MPEG 64/16	max. 18 chars.
MPEG 128/48	MPEG 128/48	max. 18 chars.
MPEG 128/32	MPEG 128/32	max. 18 chars.
MPEG 128/24	MPEG 128/24	max. 18 chars.
MPEG 128/16	MPEG 128/16	max. 18 chars.
MPEG 128/48 st	MPEG 128/48 st	max. 18 chars.
MPEG 128/32 st	MPEG 128/32 st	max. 18 chars.
MPEG 128/24 st	MPEG 128/24 st	max. 18 chars.
MPEG 128/16 st	MPEG 128/16 st	max. 18 chars.
MPEG 192/48	MPEG 192/48	max. 18 chars.
MPEG 192/32	MPEG 192/32	max. 18 chars.
MPEG 192/48 st	MPEG 192/48 st	max. 18 chars.

MPEG 192/32 st	MPEG 192/32 st	max. 18 chars.
MPEG 256/48 st	MPEG 256/48 st	max. 18 chars.
MPEG 256/32 st	MPEG 256/32 st	max. 18 chars.
MPEG 384/48 st	MPEG 384/48 st	max. 18 chars.
MPEG 384/32 st	MPEG 384/32 st	max. 18 chars.
Plat	Flat	max. 18 chars.
Coupe bas	Low cut	max. 18 chars.
Désactivé	Off	max. 18 chars.
Activé	On	max. 18 chars.
Automatique	Automatic	max. 18 chars.
Rapide (1.2 s)	Fast (1.2 s)	max. 18 chars.
Normal (6 s)	Normal (6 s)	max. 18 chars.
Lent (30 s)	Slow (30 s)	max. 18 chars.
104 dB SPL	104 dB SPL	max. 18 chars.
98 dB SPL	98 dB SPL	max. 18 chars.
92 dB SPL	92 dB SPL	max. 18 chars.
86 dB SPL	86 dB SPL	max. 18 chars.
80 dB SPL	80 dB SPL	max. 18 chars.
74 dB SPL	74 dB SPL	max. 18 chars.
Sur touches +/-	Using +/- keys	max. 18 chars.
Toujours activé	Always on	max. 18 chars.
Lecture seulement	Only in playback	max. 18 chars.
Enreg. /Nouv. index	Record/New index	max. 18 chars.
Enreg./Stop	Record/Stop	max. 18 chars.
Enreg./Marqueur	Record/Mark	max. 18 chars.
Marqueur	Mark (Rec & Play)	max. 18 chars.
Start/Stop	Start/Stop	max. 18 chars.
Non-assigné	Unassigned	max. 18 chars.
Mono (gauche)	Mono (left)	max. 18 chars.
Stéréo	Stereo	max. 18 chars.
Format FAT	FAT file system	max. 18 chars.
Format NAGRA	NAGRA file syst.	max. 18 chars.
Pile / Accu "AA"	"AA" cells	max. 18 chars.
Li-ion	Li-ion	max. 18 chars.
Mode	Mode	max. 18 chars.
Seuil déclencheur	Trigger level	max. 18 chars.
Délai déclencheur	Trigger delay	max. 18 chars.
Délai d'arrêt	Stop delay	max. 18 chars.
50 dB SPL crête	50 dB SPL peak	max. 18 chars.
60 dB SPL crête	60 dB SPL peak	max. 18 chars.
70 dB SPL crête	70 dB SPL peak	max. 18 chars.

80 dB SPL crête	80 dB SPL peak	max. 18 chars.
90 dB SPL crête	90 dB SPL peak	max. 18 chars.
100 dB SPL crête	100 dB SPL peak	max. 18 chars.
110 dB SPL crête	110 dB SPL peak	max. 18 chars.
120 dB SPL crête	120 dB SPL peak	max. 18 chars.
0.0 sec.	0.0 sec.	max. 18 chars.
0.1 sec.	0.1 sec.	max. 18 chars.
0.3 sec.	0.3 sec.	max. 18 chars.
1.0 sec.	1.0 sec.	max. 18 chars.
5 sec.	5 sec.	max. 18 chars.
15 sec.	15 sec.	max. 18 chars.
30 sec.	30 sec.	max. 18 chars.
1 min.	1 min.	max. 18 chars.
2 min.	2 min.	max. 18 chars.
5 min.	5 min.	max. 18 chars.
15 min.	15 min.	max. 18 chars.
Non-stop	Nonstop	max. 18 chars.
Activé (-6dB)	On (-6dB)	max. 18 chars.
FAT16 (max 2GB)	FAT16 (max 2GB)	max. 18 chars.
FAT32	FAT32	max. 18 chars.
Langue	Language	max. 18 chars.
English	English	max. 18 chars.
Français	Français	max. 18 chars.
Extinction autom.	Auto power off	max. 18 chars.
format inconnu	unknown format	max. 17 chars.
Fin	End	max. 11 chars.
Format	Format	max. 16 chars.
<sans titre>	<no title>	max. 17 chars.
JJ.MM.AA	DD.MM.YY	max. 8 chars.
HH:MM:SS	HH:MM:SS	max. 8 chars.
Carte en utilisation!	The card is in use!	max. 22 chars.
Pas de sélection!	No index selected!	max. 22 chars.
Effacer l'index XXX?	Delete index XXX?	1 max. 22 chars.
		2 max. 22 chars.
PRESSER LA TOUCHE ●	PRESS CENTER KEY	max. 22 chars.
CONFIRMER AVEC ►	RIGHT KEY TO CONFIRM	max. 22 chars.
Effacement ...	Deleting...	max. 22 chars.
Executé!	Done	max. 18 chars.
Echec!	Failed	max. 18 chars.
Effacer l'index XXX	Delete from index XXX?	1 max. 22 chars.
et tous les suivants?		2 max. 22 chars.

Renommer depuis l'index XXX?	Re-number from index XXX?	1	max. 22 chars.
Renommer	Re-numbering...	2	max. 22 chars.
Renommer depuis l'index 001?	Re-number from index 001?	1	max. 22 chars.
Effacer les marqueurs de l'index XXX?	Delete all marks in index XXX?	2	max. 22 chars.
Marqueurs index XXX: Effacement impossible	Marks in index XXX cannot be deleted.	1	max. 22 chars.
Aucun marqueur dans l'index XXX	No marks in index XXX.	2	max. 22 chars.
Pas de carte!	No card in slot!		max. 22 chars.
Formater en FAT16?	Format card (FAT16)?		max. 22 chars.
Formater en FAT32?	Format Card (FAT32)?		max. 22 chars.
Le contenu de la carte sera perdu!	The current content of the card will be lost!	1	max. 22 chars.
Formatage...	Formatting...	2	max. 22 chars.
Logiciel (FAT):	Soft (FAT):		max. 16 chars.
Circuit audio:	Audio board:		max. 21 chars.
Options logicielles:	Software options:		max. 22 chars.
Aucune	None		max. 22 chars.
Actuel =	Current level =		max. 16 chars.
Par défaut =	Default level =		max. 16 chars.
Muet	Mute		max. 6 chars.
Actuel =	Current contrast =		max. 19 chars.
Par défaut =	Default contrast =		max. 19 chars.
Machine occupée!	Machine busy		max. 18 chars.
Vide!	Empty		max. 18 chars.
Inexistant!	Non-existent		max. 18 chars.
ATTENTION!	WARNING!		max. 22 chars.
L'alimentation micro +48V peut endommager les micros qui n'en ont pas besoin!	Switching on the +48V phantom power supply may damage mikes which do not need it!	1	max. 22 chars.
Non-implémenté	Not implemented	2	max. 22 chars.
Nom générique: (nnn = numéro d'index)	Generic file name: (nnn = index number)	3	max. 22 chars.
Titre index XXX	Title index XXX	4	max. 22 chars.
Titrage impossible.	Titling not possible.		max. 18 chars.
Carte protégée	Card write protected.		max. 22 chars.
Cet index a été créé	This index was created	1	max. 22 chars.

avec une ancienne version de l'ARES-C.	with an old version of ARES-C.	2	max. 22 chars.
Ce titre ne peut pas être modifié.	Title can not be changed.	3	max. 22 chars.
Stop = Abandon	Stop key = Escape	1	max. 22 chars.
Lecture = Effacer	Play key = Delete	2	max. 22 chars.
>> = Insérer	>> key = Insert	3	max. 22 chars.
Enreg. = Sauvegarder	Rec. Key = Write it	4	max. 22 chars.
Carte invalide!	Invalid card!		max. 22 chars.
Carte présente.	Card present.		max. 22 chars.
Carte non-formatée.	Unformatted card.		max. 22 chars.
Trop d'index.	Too many index.	1	max. 22 chars.
Accès aux 408 premiers index?	Access first 408 indexes?	2	max. 22 chars.
Fichier non-fermé.	Unclosed file.	3	max. 22 chars.
Récupérer?	Recover?	1	max. 22 chars.
		2	max. 22 chars.
		3	max. 22 chars.
Erreur X	Error X		max. 22 chars.
index XXX corrompu.	index XXX corrupted.		max. 22 chars.
Eff. -> fin de carte?	Clean to end of card?		max. 22 chars.
Format sans problème.	No format problems.		max. 22 chars.
408 index disponible.	408 indexes available.		max. 22 chars.
Effacement...	Cleaning...		max. 22 chars.
Logiciel (NFS)	Soft (NFS):		max. 16 chars.
GAIN INADAPTE	AUTO REC LEVEL ERR.		max. 20 chars.
REPertoire PLEIN	DIRECTORY FULL		max. 19 chars.
ERREUR VERSION USB	WRONG USB VERSION		max. 19 chars.
Clavier verrouillé	Keypad locked		max. 19 chars.
CARTE PLEINE	CARD FULL		max. 19 chars.
ERREUR D'OUVERTURE	OPEN WRITE ERROR		max. 19 chars.
ERREUR D'ECRITURE	WRITE ERROR		max. 19 chars.
ERREUR DE LECTURE	READ ERROR		max. 19 chars.
CARTE TROP LENTE	CARD TOO SLOW		max. 19 chars.
CARTE QUASI PLEINE	CARD NEARLY FULL		max. 19 chars.
EXTINCTION AUTOM.	AUTO POWER OFF		max. 19 chars.
BATTERIE DECHARGEE	LOW BATTERY		max. 19 chars.
Extinct. désactivée	No auto power off		max. 19 chars.
CARTE PROTEGEE	CARD WRITE PROTECT		max. 19 chars.
TAMPON DEBORDE	BUFFER OVERFLOW		max. 19 chars.
CLAVIER VERROUILLE	KEYPAD LOCKED		max. 21 chars.
Presser & maintenir	Press & hold	1	max. 22 chars.

les touches ◀ & ▶ pour le déverrouiller.	left & right keys to release.	2	max. 22 chars.
CARTE INVALIDE	INVALID CARD	3	max. 22 chars.
PAS DE CARTE	NO CARD		max. 21 chars.
FORMAT INCONNU	UNKNOWN FORMAT		max. 21 chars.
REPERT INUTILISABLE	DIR UNUSABLE		max. 21 chars.
Lecture...	Card reading...		max. 21 chars.
Carte occupée...	Card busy...		max. 21 chars.
Mode USB	USB mode		max. 21 chars.
FORMAT CORROMPU	FORMAT CORRUPTED		max. 21 chars.
ERREUR LECTURE CARTE	CARD READ ERROR		max. 21 chars.
CARTE NON-FORMATEE	UNFORMATTED CARD		max. 21 chars.
Mode distant	Remode mode		max. 21 chars.
Entrée	In		max. 7 chars.
Sortie	Out		max. 7 chars.
Seuil	Thr		max. 7 chars.
Muet	Off		max. 5 chars.
Index	Index		max. 6 chars.
Début	Begin		max. 9 chars.
Fin	End		max. 9 chars.
Stop boucle	End loop		max. 19 chars.
Ecoute boucle/Ajust	Listen loop/Trim		max. 19 chars.
Placer une coupe	Place cut		max. 19 chars.
Ajust segm. gauche	Slide left segment		max. 19 chars.
Ajust segm. droite	Slide right segment		max. 19 chars.
Incrément/Ecoute	Step/Listen		max. 19 chars.
Eff. coupe	Delete cut		max. 12 chars.
Restaure seg.	Undo cut out		max. 12 chars.
Eff. segment	Del segment		max. 12 chars.
Fin	Exit		max. 5 chars.
Index XXX	Index XXX		max. 22 chars.
Durée édit.:	Edit length:		max. 12 chars.
Reste carte:	Remain:		max. 12 chars.
Edition	Edit		max. 7 chars.
Sauvegarde	Save		max. 10 chars.
Abandon	Quit directory		max. 22 chars.
Index XXX créé	Index XXX created		max. 22 chars.
Erreur de lecture	Read error		max. 22 chars.
Erreur d'écriture	Write error		max. 22 chars.
Err. creation d'index	Unable to create index		max. 22 chars.
Interrompu	Aborted		max. 22 chars.

Saut automatique	Automatic skip	max. 22 chars.
Index en boucle	Index loop	max. 22 chars.
Config. Start / Stop	Start / Stop config.	max. 22 chars.
Fader start	Fader start	max. 22 chars.
Erreur	Error	max. 22 chars.
Presser une touche	Press any key	max. 22 chars.
Création index XXX	Creating index XXX	max. 22 chars.
Annuler sauvegarde	Abort saving	max. 20 chars.
Format de nom	File name format	max. 18 chars.
Machine	Machine	max. 18 chars.
Machine_heure	Machine_time	max. 18 chars.
Machine_date	Machine_date	max. 18 chars.
Machine_date_heure	Machine_date_time	max. 18 chars.
Carte	Card	max. 18 chars.
Carte_heure	Card_time	max. 18 chars.
Carte_date	Card_date	max. 18 chars.
Carte_date_heure	Card_date_time	max. 18 chars.
Nom de carte	Card name	max. 18 chars.
Nom de machine	Machine name	max. 18 chars.
Niveau d'entrée	Input level	max. 18 chars.
Normal	Normal	max. 18 chars.
Verrouillé	Locked	max. 18 chars.

## 26 SPECIFICATIONS

### GENERAL

Data Storage medium	PCMCIA ATA cards, Compact flash cards, Micro drives
Recording Method	Digital (PCM) or Digital compression
Compression type	ISO MPEG Layer II*
A/D & D/A conversion	20 Bit Sigma-Delta
Sampling Rate	16, 22.05, 24, 32, 44.1, 48 kHz
Bit-Rates	64, 128, 192, 256, 384 kb/s*
Mono/Stereo	Switchable and input routing
Recording Capacity	1 hour 26 minutes on a 1 GB card Stereo 48 kHz PCM, 34 hours 45* minutes on a 1 GB card Mono 48 kHz 64 kb/s
PCMCIA Slot	Single type I & II
Dynamic Range Adjust	50 dB for 0 dB record (manual), 40 dB for 0 dB record (ALC)
Filters	"Flat", "LFA"
File Format	Broadcast Wave Format (.wav)

### INPUTS

Mic. / Line Inputs	2 XLR connectors
Microphone Powering	48 V Phantom
Sensitivity	From 2 mV to 10 mV for 0 dB recording
Line Input	Symmetrical transformerless
Line Input Sensitivity	0.44 V to 2.6 V for 0 dB recording

### OUTPUTS

Headphone	Jack 6.3 mm stereo connector MS decoding
Line Output	2 XLR connectors, symmetrical transformerless
THD at 1 kHz	0.1 %
Frequency response	30 Hz – 20 kHz (-3 dB in EE mode)
Total dynamic range	80 dB

### POWER SUPPLY

Battery pack	6 x "AA" cells
Lithium Ion pack	2400 mAh
Consumption	9 V - 150 mA, 7.2 V – 185 mA during record (no display light)

### PHYSICAL

Dimensions	160 x 168 x 56 mm (6¼ x 6¾ x 2 inch)
Weight	900 g. (2 lb)

(\* including the MPEG option)

Note: We have not tested all available cards and adapters on the market. Therefore we cannot guaranty the perfect operation in the Nagra machines. Cards and adapters supplied by Nagra are guaranteed to operate within the machine specifications.

# DECLARATION DE CONFORMITE DECLARATION OF CONFORMITY

**FABRICANT:** NAGRAVISION S.A. KUDELSKI GROUP, 1033 CHESEAUX SUISSE  
**MANUFACTURER:** NAGRAVISION S.A. KUDELSKI GROUP 1033 CHESEAUX, SWITZERLAND

**APPAREIL :** ARES-BB<sup>+</sup> & alimentation secteur NB-PSU  
**MODEL:** ARES-BB<sup>+</sup> & mains power adapter NB-PSU

**NORMES APPLICABLES :**  
**APPLICABLE NORMS:**

Champ électromagnétique rayonné <i>Radiated electromagnetic field</i>	EN 55022 Cl. B <i>EN 55022 Cl. B</i>
Perturbations conduites sur secteur <i>Disturbance voltage on mains terminal</i>	EN 55022 Cl. B <i>EN 55022 Cl. B</i>
Immunité aux champs électromagnétiques <i>Immunity to electromagnetic fields</i>	EN 61000-4-3 <i>EN 61000-4-3</i>
Immunité aux décharges électrostatiques <i>Immunity to electrostatic discharges</i>	EN 61000-4-2 <i>EN 61000-4-2</i>
Immunité aux transitoires électriques rapides en salves sur câble d'alimentation <i>Immunity to burst on mains line</i>	EN 61000-4-4 level 2 (1000V) <i>EN 61000-4-4 level 2 (1000V)</i>
Immunité aux transitoires électriques rapides en salves sur câbles d'entrées/sorties signaux <i>Immunity to burst on input/output line</i>	EN 61000-4-4 level 1 (500V) <i>EN 61000-4-4 level 1 (500V)</i>
Immunité aux ondes de choc <i>Immunity to surge</i>	EN 61000-4-5 level 2 (1000V) <i>EN 61000-4-5 level 2 (1000V)</i>

Cheseaux 3<sup>e</sup> trimestre 2004  
Cheseaux 3<sup>th</sup> quarter 2004

**NAGRAVISION SA KUDELSKI GROUP**  
**Route de Genève 22**  
**CH-1033 Cheseaux**  
**Switzerland**

**Phone +41 (0)21 732-0101**  
**Fax +41 (0)21 732-0100**  
**E-mail [info@nagra.com](mailto:info@nagra.com)**

All rights reserved-© July 18, 2006